

1100

PORTABLE HOSE REELS ON WHEELS

To handle 3/8" through 5/8" I.D. hose.

- Continuous flow reels with swivel joint inlet, fluid hub, outlet riser.
- Comes with cam lock brake.
- Direct crank rewind.
- One-piece foot, rubber tires, and removable steel handlebar.
- Permanently attached crank.
- Standard inlet 90° ball bearing swivel joint 1/2" female NPT threads.
- Standard outlet is 1/2" female NPT threads.
- Prefix GH to model number when ordering garden hose thread, e.g., GH1100.
- Pressures to 3000 psi (207 bar).
- Temperatures from +20° F to +400° F (-7° C to +204° C).



GH 1100 Configuration Shown

For:

- Grounds Maintenance
- Restaurants/Hotels
- Home Use

| Model Number | Hose Capacity of Reel | | | | Approx. Weight | |
|--------------|------------------------|-----------|-----------|-----------|----------------|-----------|
| | | feet | m. | | lb. | kg. |
| | I.D. (in) I.D. (mm) | 3/8" | 1/2" | 5/8" | NET | SHIP |
| | O.D. (in) O.D. (mm) | 3/4" | 7/8" | 1" | | |
| 1100 | | 300 91 | 200 61 | 150 46 | 47 21 | 50* 23 |

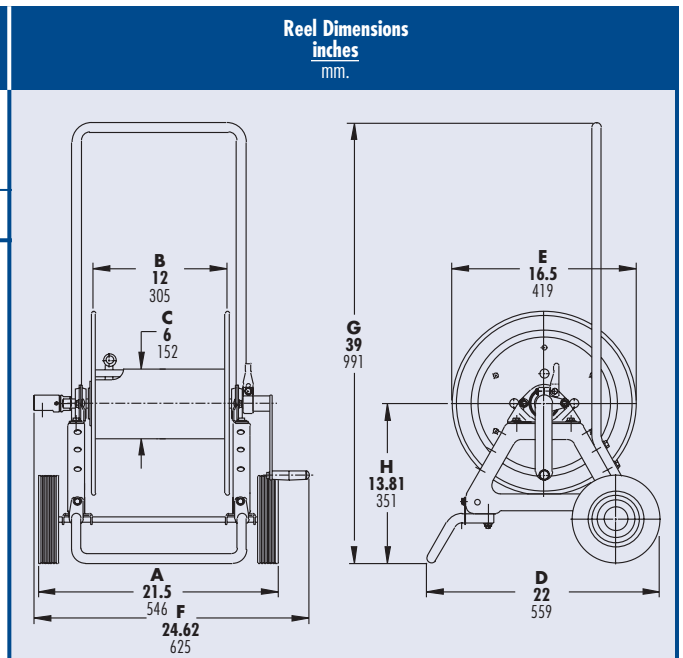

Notes:

1. Specifications subject to change.
 2. For a detailed parts breakdown drawing, request ISO 48.
 3. **Finish:** refer to Page 4.
 4. **Be sure to check dimensions and weights prior to ordering.**
- * When shipped as a parcel package (via Fed-Ex or UPS Ground).