

AT1200

PORTABLE HOSE REELS ON WHEELS

To handle 1/2" through 1" I.D. hose.

- Continuous flow reels with swivel joint inlet, fluid hub, outlet riser.
- Comes with pneumatic tires and spring tension brake.
- Direct crank rewind.
- One-piece foot, rubber tires, and removable steel handlebar.
- Permanently attached crank.
- Model AT1200 –standard inlet 90° balance pressure swivel joint 1" female NPT threads.
- Standard outlet is 1" female NPT threads.
- Prefix GH to model number when ordering garden hose thread, e.g., GHAT1200.
- Operates at pressures to 1000 psi.
- Temperatures from -40° F to +250° F (-40° C to +121° C).
- Consult factory for other pressures & temps.



GHAT 1200 Configuration Shown

For:

- Grounds Maintenance
- Restaurants/Hotels
- Home Use

Model Number	Hose Capacity of Reel					Approx. Weight	
		1/2"	5/8"	3/4"	1"	lb.	kg.
	I.D. (in)	13	16	19	25		
	I.D. (mm)	330	250	150	100	NET	SHIP
	O.D. (in)	22	25	33	40	86	91*
	O.D. (mm)	107	76	46	30	39	41
AT1200							

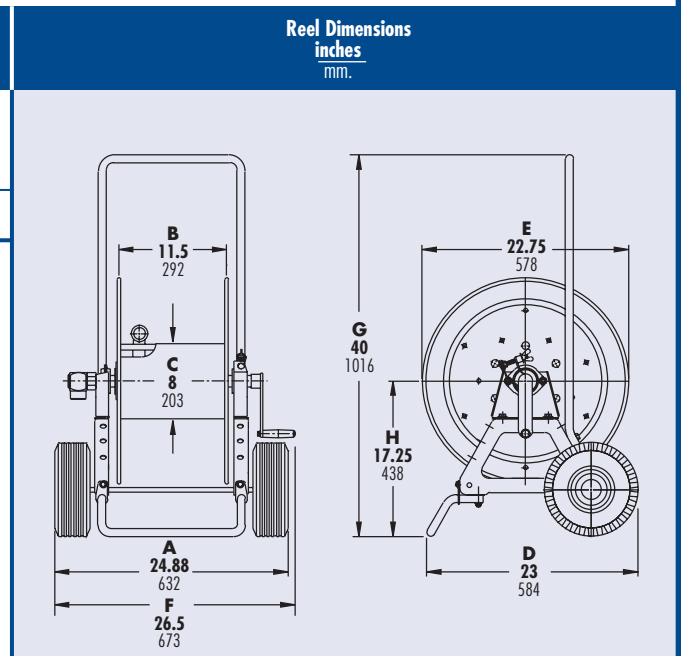

Notes:

1. Specifications subject to change.
 2. For a detailed parts breakdown drawing, request ISO 87.
 3. **Finish:** refer to Page 4.
 4. **Be sure to check dimensions and weights prior to ordering.**
- *When shipped as a parcel package (via Fed-Ex or UPS Ground)