

C1150

PORTABLE STORAGE REELS ON WHEELS

- Direct crank rewind
- One-piece foot, rubber tires, and removable steel handlebar
- For storing cable, hose or rope. A 1-1/8" x 2-3/8" (28 mm x 60 mm) opening in the drum to initiate winding.
- Comes with cam lock brake.



Standard Configuration Shown

For:

- Industrial Maintenance
- Construction
- Agriculture
- Grounds Maintenance

Model Number	Cable Capacity of Reel feet m.				Approx. Weight lb. kg.	
	Gauge/Number of Conductors				NET	SHIP
	O.D. (in) O.D. (mm)	16/3 10	14/3 14	12/3 15		
C1150	1100 335	500 152	400 122	300 91	44 20	50* 23

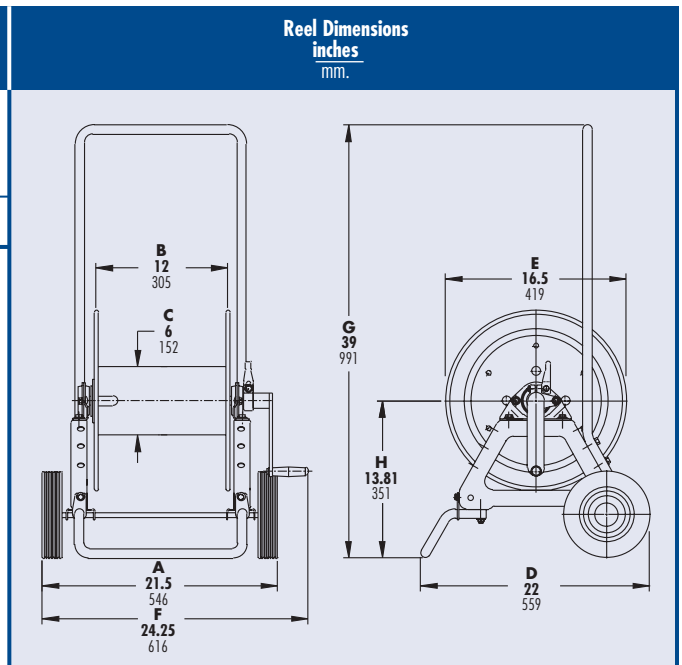

Notes:

1. Specifications subject to change.
2. When ordering specify model number, O.D., length and weight of cable, hose, etc.
3. For a detailed parts breakdown drawing, request ISO 48.
4. **Finish:** refer to Page 4.

5. Be sure to check dimensions and weights prior to ordering.

*When shipped as a parcel package (via Fed-Ex or UPS Ground), some assembly required.