

# C3200

## MANUAL REWIND STORAGE REELS

To handle single 1/2" through 1-1/2" O.D.

- A 4-1/2" x 9" (114mm x 229mm) opening in the drum to initiate winding.
- Designed for storage of long lengths of hose, cable, rope, wire or other materials.
- Choose disc rewind or removable direct crank rewind.
- Supplied with spring actuated pin lock.
- Optional divider discs can be placed at almost any point. Be sure to specify spacing of discs on your order.
- Rollers may be purchased as accessory items.

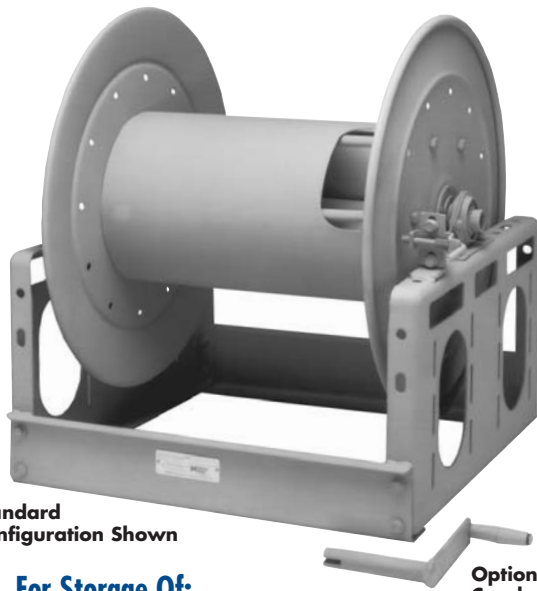

Standard Configuration Shown

Optional Crank Handle

For Storage Of:

- Hose
- Cable
- Rope
- Wire

Model Number	Hose Capacity of Reel						Approx. Weight		Reel Dimensions***						
	O.D. (in) O.D. (mm)	1/2" 13	3/4" 19	1" 25	1-1/4" 32	1-1/2" 38	NET	SHIP	A	B	E CRANK	F CRANK	G	H	X
C3218-25-26		1000 305	450 137	225 69	125 38	90 27	85 39	127 58	15 381	9.5 241	24.75 629	22 559	27.88 708	15.5 394	7 178
C3228-25-26		–	1000 305	500 152	325 99	200 61	109 49	151 68	25.5 648	20 508	24.75 629	32.5 826	27.88 708	15.5 394	17.5 445
C3234-25-26		–	1300 396	650 198	400 122	275 84	122 55	164 74	31.5 800	26 660	24.75 629	38.5 978	27.88 708	15.5 394	23.5 597

**Notes:**

1. Specifications subject to change.
  2. Upon request, reels can be supplied with drum lengths other than shown and with disc sizes in other dimensions.
  3. Dimensions reflect pressed frames.
  4. For a detailed parts breakdown drawing, request ISO 117.
  5. Series C3200 requires 3-1/2" clearance to remove crank handle.
  6. Subtract 5" from 'F' dimension for disc rewind on C3200 Series.
  7. **Finish:** refer to Page 4.
  8. **Be sure to check dimensions and weights prior to ordering.**
- \*\*\* x,y indicate mounting holes. See page 2

