

1500

MANUAL OR POWER REWIND REELS

To handle single 1/4" through 5/8" I.D. hose.

- Lightweight compact reels designed for long lengths of hose in manual and power rewind.
- Direct crank rewind is permanently attached.
- Chain and sprocket drive powered by electric, hydraulic, or compressed air motor.
- Direct crank rewind, cam lock drag brake, spring actuated pin lock.
- Standard inlet 90° ball bearing swivel joint 1/2" female NPT threads.
- Standard outlet 1/2" female NPT threads.
- Optional Rollers: Specify roller position when ordering.
- Pressures to 3000 psi (207 bar)
- Temperatures from +20° F to +400° F (-7° C to +204° C).
- Consult factory for other pressures & temps.



Power Rewind Standard Configuration Shown

For:

- Lawn Care
- Pest Control
- Pressure Washing
- Agriculture
- Steam Cleaning

| Model Number | Hose Capacity of Reel | | | | | Approx. Weight | | Reel Dimensions*** | | | | |
|--------------------------------|-----------------------|------------|------------|------------|------------|---------------------------|-----------|--------------------|-----------|------------|-------------|-------------|
| | feet m. | | | | | Crank Rewind ³ | | inches mm. | | | | |
| For Power Rewind See Note 5 | I.D. (in) | 1/4" | 3/8" | 1/2" | 5/8" | NET | SHIP | E CRANK | E POWER | F CRANK | F POWER | X |
| | I.D. (mm) | 6 | 10 | 13 | 16 | | | | | | | |
| 1514-17-18 | | 200 61 | 150 46 | 100 30 | 75 23 | 27 12 | 50* 23 | 16.5 419 | 19 483 | 19 483 | 16.5 419 | 9.5 241 |
| 1520-17-18 | | 425 130 | 300 91 | 200 61 | 150 46 | 29 13 | 50* 23 | 16.5 419 | 19 483 | 25 635 | 22.5 572 | 15.5 394 |
| 1526-17-18 | | 625 191 | 450 137 | 325 99 | 225 69 | 31 14 | 50* 23 | 16.5 419 | 19 483 | 31 787 | 28.5 724 | 21.5 546 |
| 1530-17-18 | | - | 550 168 | 400 122 | 300 91 | 33 15 | 50* 23 | 16.5 419 | 19 483 | 35 889 | 32.5 826 | 25.5 648 |
| 1536-17-18 | | - | - | 500 152 | 375 114 | 35 16 | 50* 23 | 16.5 419 | 19 483 | 41 1041 | 38.5 978 | 31.5 800 |

Notes:

- Specifications subject to change.
- Upon request, reels can be supplied with drum lengths other than shown.
- Weights shown in chart are for crank rewind models. ADD these amounts for power rewind models:

| | Net (lbs.) | Ship (lbs.) | Net (kg.) | Ship (kg.) |
|-----------|------------|-------------|-----------|------------|
| Electric | 18 | 18 | 8.2 | 8.2 |
| Hydraulic | 15 | 15 | 6.8 | 6.8 |
| Air | 15 | 15 | 6.8 | 6.8 |
- Dimension "F" is the overall length of standard model reels.
- When ordering power rewind models, prefix model number with:
 - A = Air Rewind
 - E = Electric Rewind
 - HD = Hydraulic Rewind
 (Air rewind reels are supplied with control valve and hose; 12v and 24v DC rewind reels are supplied with switch and solenoid; 115v AC rewind reels are not supplied with switch but can be ordered separately; hydraulic rewind reels are not supplied with control valve.)
- For a detailed parts breakdown drawing, request ISO 90.
- Finish:** refer to Page 4.

8. Be sure to check dimensions and weights prior to ordering.

NOTICE: A Flexible Connector must be used between the inlet pipe and the inlet swivel joint.

* When shipped as a parcel package (via Fed-Ex or UPS Ground).

*** x,y indicate mounting holes. See page 2

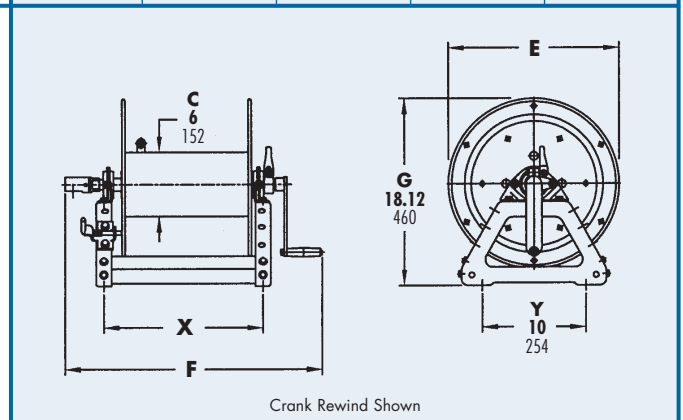

Crank Rewind Shown