

2000

MANUAL OR POWER REWIND REELS

To handle dual 1/4" through 1/2" I.D. hose.

- Two swivel joint inlets and two outlet risers to handle two equal lengths of hose.
- Chain-drive crank rewind or chain and sprocket rewind powered by an electric, or compressed air motor.
- MX Crank rewind reels pinion brake as standard.
- Power rewind reels are not supplied with a brake.
- Standard inlets 90° ball bearing swivel joints 1/2" female NPT threads.
- Standard outlets 1/2" female NPT threads.
- Pressures to 3000 psi (207 bar).
- Temperatures from +20° F to +400° F (-7° C to +204° C).
- Consult factory for other pressures & temps.
- Reels for use with oxygen/acetylene.

See Series 2400 Hannay Reels Welding Catalog H9422-W.



Standard Configuration Shown

- For:
- Hydraulics
 - Air/Water

Model Number	Hose Capacity of Reel feet m.				Approx. Weight Crank Rewind ³ lb. kg.		Reel Dimensions*** inches mm.				
	I.D. (in) I.D. (mm)	1/4" 6	3/8" 10	1/2" 13	NET	SHIP	E CRANK	E POWER	F CRANK	F POWER	X
For Power Rewind See Note 5	O.D. (in) O.D. (mm)	5/8" 16	3/4" 19	7/8" 22							
2016-17-18		2/125 2/38	2/100 2/31	2/50 2/15	32 15	50* 23	18.5 470	19 483	21 533	20.75 527	11.5 292
2020-17-18		2/200 2/61	2/150 2/46	2/100 2/31	34 15	50* 23	18.5 470	19 483	25 635	24.75 629	15.5 394
2026-17-18		2/300 2/91	2/225 2/69	2/150 2/46	36 16	50* 23	18.5 470	19 483	31 787	30.75 781	21.5 546
2030-17-18		2/375 2/114	2/250 2/76	2/175 2/53	37 17	50* 23	18.5 470	19 483	35 889	34.75 883	25.5 648
2036-17-18		2/475 2/145	2/350 2/107	2/250 2/76	39 18	50 23	18.5 470	19 483	41 1041	40.75 1035	31.5 800

Notes:

1. Specifications subject to change.
2. Upon request, reels can be supplied with drum lengths other than shown and with disc sizes in other diameters.
3. Weights shown in chart are for crank rewind models. ADD these amounts for power rewind models:

	Net (lbs.)	Ship (lbs.)	Net (kg.)	Ship (kg.)
Electric	18	18	8.2	8.2
Air	15	15	6.8	6.8

4. Dimension "F" is the overall length of standard model reels. MX chain drive crank models, reels require 2" clearance to remove crank handle.
5. When ordering, prefix model number with:
A = Air Rewind E = Electric Rewind
MX = Chain Drive Crank
(Air rewind reels are supplied with control valve and hose;
12v and 24v DC rewind reels are supplied with switch and solenoid;
115v AC rewind reels are not supplied with switch but can be ordered separately.)
6. For a detailed parts breakdown drawing, request ISO 112.
7. **Finish:** refer to Page 4.
8. **Be sure to check dimensions and weights prior to ordering.**

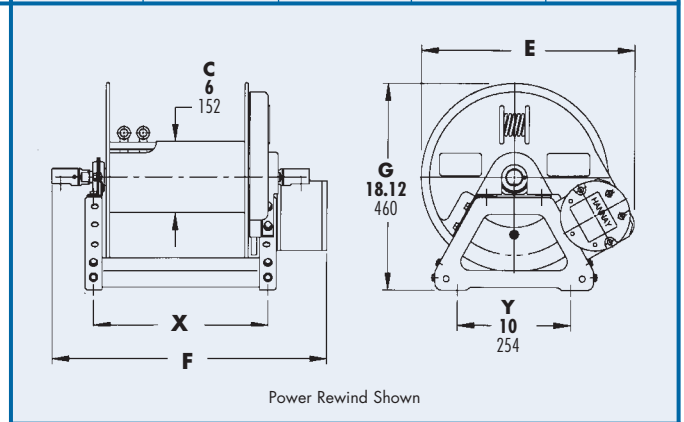

Power Rewind Shown

NOTICE: A Flexible Connector must be used between the inlet pipe and the inlet swivel joint.

* When shipped as a parcel package (via Fed-Ex or UPS Ground).
*** x,y indicate mounting holes. See page 2