

4000

MANUAL OR POWER REWIND REELS

To handle single 3/4" or 1" I.D. hose.

- Lightweight compact reels designed for long lengths of hose in manual and power rewind.
- Direct crank rewind is removable.
- Chain and sprocket drive powered by electric, hydraulic, or compressed air motor.
- Direct crank rewind, adjustable spring tension brake, spring actuated pin lock.
- Standard inlet 90° ball bearing swivel joint 1" female NPT threads.
- Standard outlet 1" female NPT threads.
- Optional Rollers: Specify roller position when ordering.
- Pressures to 1000 psi (69 bar).
- Temperatures from -60° F to +250° F (-51° C to +121° C).
- Consult factory for other pressures & temps.



Electric Rewind Standard Configuration Shown

For:

- Fuel Dispensing
- Fire Protection
- Water Supply
- Chemical Transfer

Model Number	Hose Capacity of Reel			Approx. Weight Crank Rewind ³		Reel Dimensions***				
	I.D. (in) I.D. (mm)	3/4" 19	1" 25	NET	SHIP	E CRANK	E POWER	F CRANK	F POWER	X
For Power Rewind See Note 5	O.D. (in) O.D. (mm)	1-9/32" 33	1-9/16" 40							
4018-17-18		50 15	35 11	36 16	50* 23	16.5 419	19 483	25.88 657	20.5 521	13.5 343
4024-17-18		100 30	50 15	46 21	56* 25	16.5 419	19 483	31.88 810	26.5 673	19.5 495
4030-17-18		150 46	75 23	57 26	62* 28	16.5 419	19 483	37.88 962	32.5 826	25.5 648
4038-17-18		200 61	100 30	70 32	112 51	16.5 419	19 483	45.88 1165	40.5 1029	33.5 851

Notes:

1. Specifications subject to change.
2. Upon request, reels can be supplied with drum lengths other than shown.
3. Weights shown in chart are for crank rewind models. ADD these amounts for power rewind models:

	Net (lbs.)	Ship (lbs.)	Net (kg.)	Ship (kg.)
Electric	18	18	8.2	8.2
Hydraulic	15	15	6.8	6.8
Air	15	15	6.8	6.8
4. Dimension "F" is the overall length of standard model reels. Crank rewind reels require 3-1/2" clearance to remove or install crank handle.
5. When ordering power rewind models, prefix model number with:
 - A = Air Rewind
 - E = Electric Rewind
 - HD = Hydraulic Rewind
 (Air rewind reels are supplied with control valve and hose; 12v and 24v DC rewind reels are supplied with switch and solenoid; 115v AC rewind reels are not supplied with switch but can be ordered separately; hydraulic rewind reels are not supplied with control valve.)
6. For a detailed parts breakdown drawing, request ISO 68.
7. **Finish:** refer to Page 4.
8. **Be sure to check dimensions and weights prior to ordering.**

NOTICE: A Flexible Connector must be used between the inlet pipe and the inlet swivel joint.

* When shipped as a parcel package (via Fed-Ex or UPS Ground).

*** x,y indicate mounting holes. See page 2

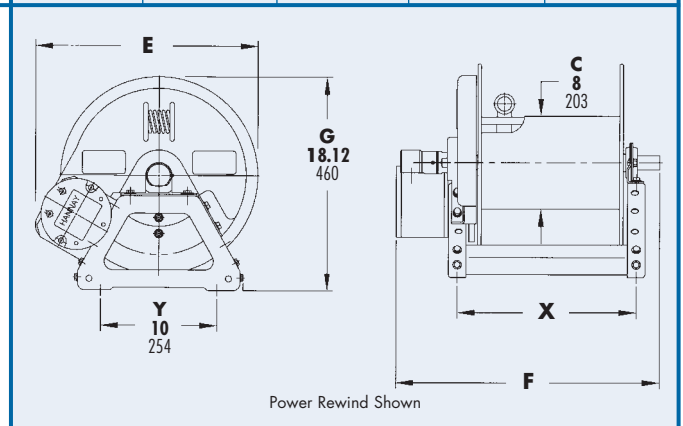

Power Rewind Shown