

SCR700/NSCR700

SPRING REWIND REELS

To handle live electric cable.

- Heavy-duty spring motor.
- Non sparking ratchet.
- Declutching arbor.
- Consult factory for constant tension applications.
- 3-conductor 45 amp 600 volt collector assembly with #8 gauge wiring.
- Double brushes per circuit. Brushes are copper graphite with copper alloy rings.
- Additional conductors or higher amperage (up to 300 amps) available, consult factory.
- Silver collector available.
- Supplied with a 4-way roller assembly. Roller position must be specified.
- A cable stop should be used.
- For vertical lift, stretch and/or crane installation, consult factory for proper spring specifications.



Series SCR700
Standard Configuration shown



Series NSCR700
Standard Configuration shown

SCR700/NSCR700

Parts Drawing: Series SCR700 – ISO 49, Series NSCR700 – ISO 164

Model Number	Cable Capacity of Reel feet m.				Approx. Weight lb. kg.		Roller Assembly	Reel Dimensions*** inches mm.																
	GA./NO. OF CONDUCTORS				NET	SHIP		A	N/A	B	C	D	E	N/E	F	N/F	G	N/G	H	N/H	X	N/X	Y	
	14/3	12/3	10/3	8/3																				
Delete Prefix N for Channel Frame	O.D.	.530" 14mm	.600" 15mm	.690" 18mm	.750" 19mm																			
NSCR715-14-16C		35 11	25 8	-	-	59 27	74 34	N203	-	9 229	3 76	8 203	-	-	17.62 448	-	13.75 349	-	16.12 409	-	9.12 232	-	7 178	-
NSCR715-16-17C		40 12	35 11	-	-	62 28	77 35	N203	-	9 229	3 76	10.5 267	-	-	18.5 470	-	13.75 349	-	17 432	-	9.12 232	-	7 178	-
NSCR715-19-20J		50 15	50 15	50 15	50 15	74 34	109 49	N204	8.25 210	9 229	3 76	10.5 267	18 457	19.5 495	20.75 527	15.25 387	13.75 349	19.75 502	20 508	10.38 264	10.62 270	3.5 89	7 178	15 381
NSCR716-23-24B		75 23	75 23	75 23	75 23	99 45	134 61	N204	9.25 235	10 254	4 102	15.5 394	23.25 591	24.38 619	23.75 603	16.25 413	14.75 375	23.88 607	24 610	12.5 318	12.62 321	4.5 114	8 203	20.25 514
NSCR716-23-24G		100 30	100 30	-	-	105 48	140 64	N204	9.25 235	10 254	4 102	15.5 394	23.25 591	24.38 619	23.75 603	16.25 413	14.75 375	23.88 607	24 610	12.5 318	12.62 321	4.5 114	8 203	20.25 514
SCR716-30-31-20A		120 37	120 37	120 37	120 37	127 58	162 73	R204	9.25 235	-	4 102	20 508	28.5 724	29.62 752	-	17 432	-	31.38 797	-	17 432	-	4.5 114	-	25.5 648

Notes:

1. Specifications subject to change.
 2. For reels with 4-conductor 45 amp collector assemblies, add 2" to "F" dimension.
 3. Reel models and capacities shown are for standard drag applications; for vertical lift applications consult factory.
 4. Other sizes from standard components, available upon request.
 - 5. Be sure to check dimensions and weights prior to ordering.**
 6. Roller assembly is supplied on standard models.
- ***x,y indicate mounting holes

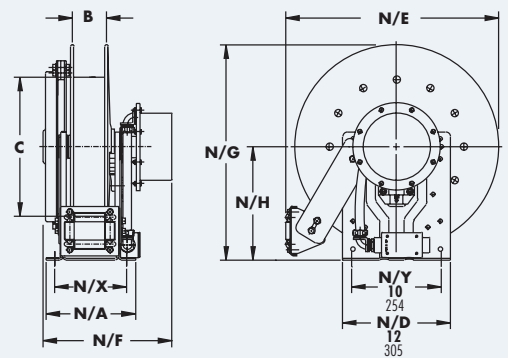
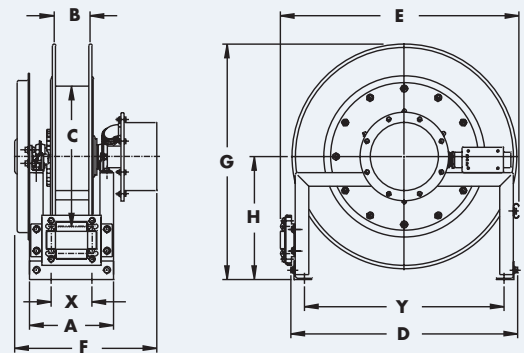

Roller Positions Available

